

GW 2020

# Planning Blocks



Overview	3
Folder Structure	4
CAD Blocks	5
Planning Blocks:	
Beds	6
Mattresses	7
Chest of Drawers	14
Storage	16
Planning	19
BTIs	22
Media	23
Graphics	25
IMS Racking	26
Digital	27
Digital Overview	28
Data and Electric:	
Beds	29
Mattresses	30
PAX and Open Storage	31
Planning Area	32



- Blocks in both CAD and Sketchup include all elements (ex. Coordination Areas, Perimeter Breaks, Showcases : millwork, racking, furniture, etc.) on the appropriate layers. Some CAD blocks will need to be exploded before creating final PDFs.
- All partitions (Planning and Mattress high partitions and Low Partition) to be placed on NOTES layer. Please let Morten know so he can place on drawing. He will provide Millwork dimension drawing for partitions only. Specialists will need to provide dimensions for any other millwork as needed.
- Blocks are available for 260cm and 290cm height stores where applicable.
- 260cm height stores:
  - **Brooklyn**
  - Paramus
  - Elizabeth
  - Long Island
  - College Park
  - Stoughton
  - **Emeryville**
  - **Portland**
  - **East Palo Alto**
  - Covina
  - **Costa Mesa**
  - Bolingbrook
- 290cm height stores:
  - **Burbank**
  - **Renton**
  - **Centennial**
  - Schaumburg

- FORBO Flooring: Morten will provide total area sq. ft. as well as layout with flooring direction directly to supplier. Specialists only need to spec PURLINE on FI schedule and layout dimensions (ex. Vitality Area)
- Props will be documented in Solution Books.
- Specialists will be responsible for filling out Millwork and Plexi spreadsheets for vendor orders.
- On Morten's drawing:
  - Partitions
  - Data and Electric
  - Faay walls
- Planning Tools:
  - CAD Blocks
  - SketchUp Blocks
- Documentation Tools:
  - Flooring snips
  - Paint snips
  - Media solutions library
  - PA specific libraries



# GWI 2020 | Folder Structure

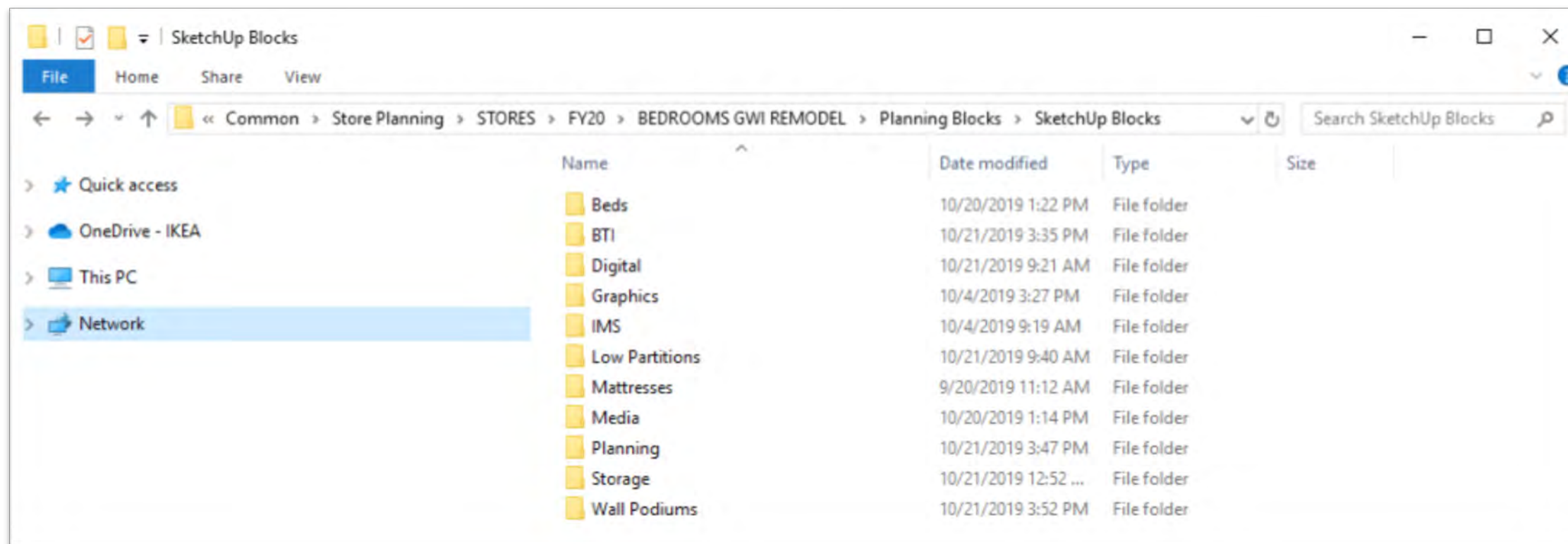
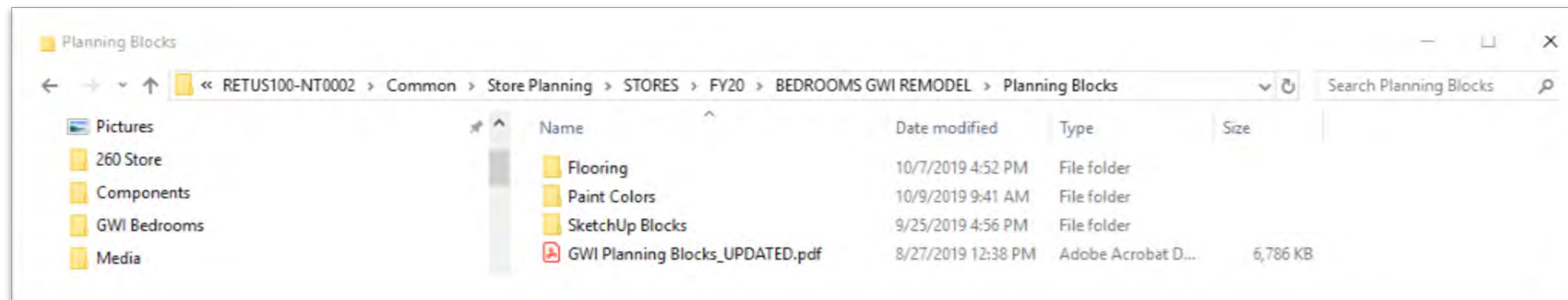
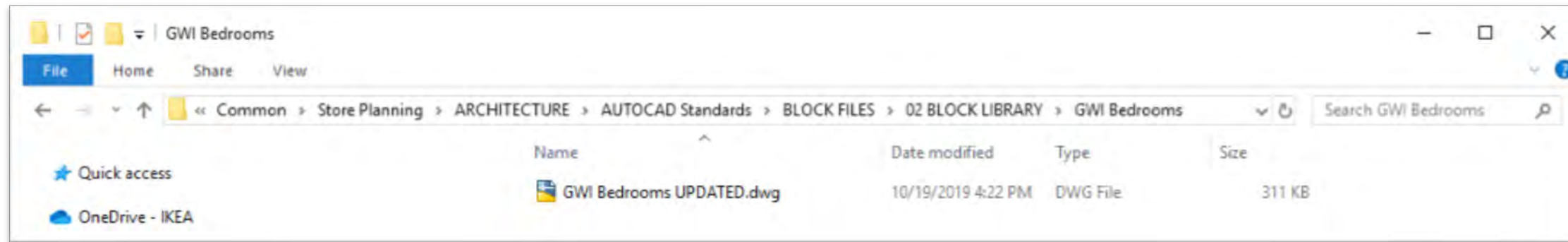

## GWJ 2020 | CAD Blocks

- Place these blocks onto the MILLWORK layer
- The following CAD blocks contain all elements (millwork, racking, furniture, etc.): Mattress Showcase, Bedside Tables, Planning Desks, PAX Showcases, PAX Door Menus, Perimeter Breaks, and Coordination Areas. Once you pull in the block and explode it, each component will be on its proper layer and can be adjusted as needed. Please DO NOT manipulate Millwork.
- Some blocks are now dynamic!

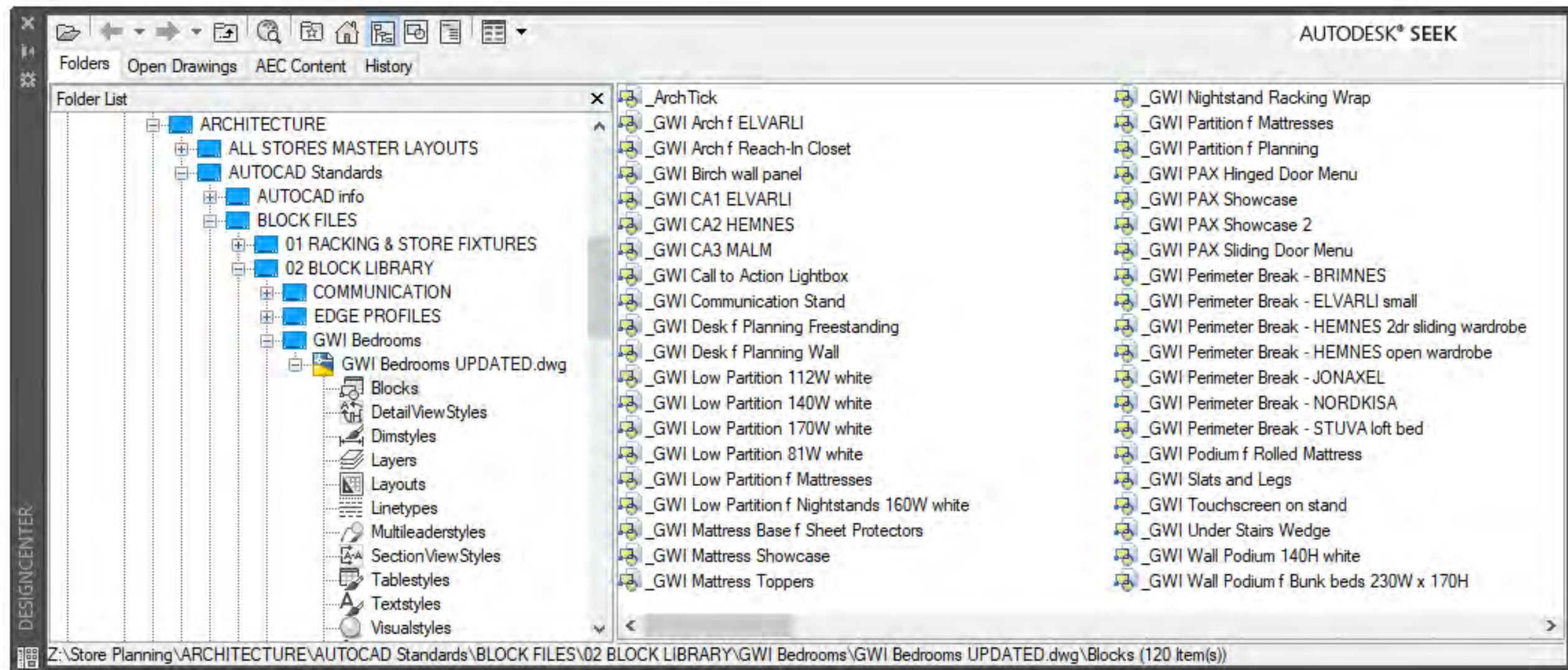

- SketchUp file includes all elements: millwork, racking, and displays.

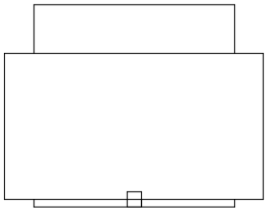
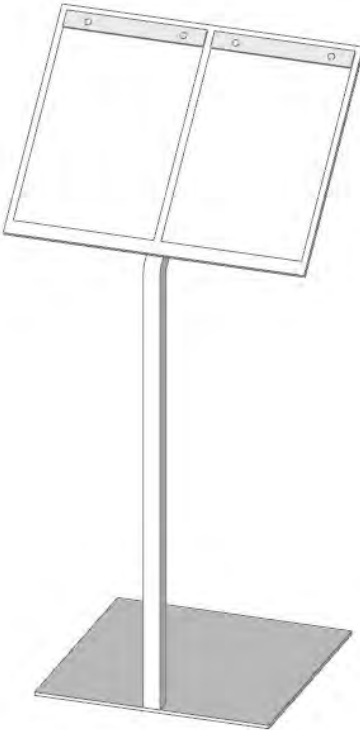
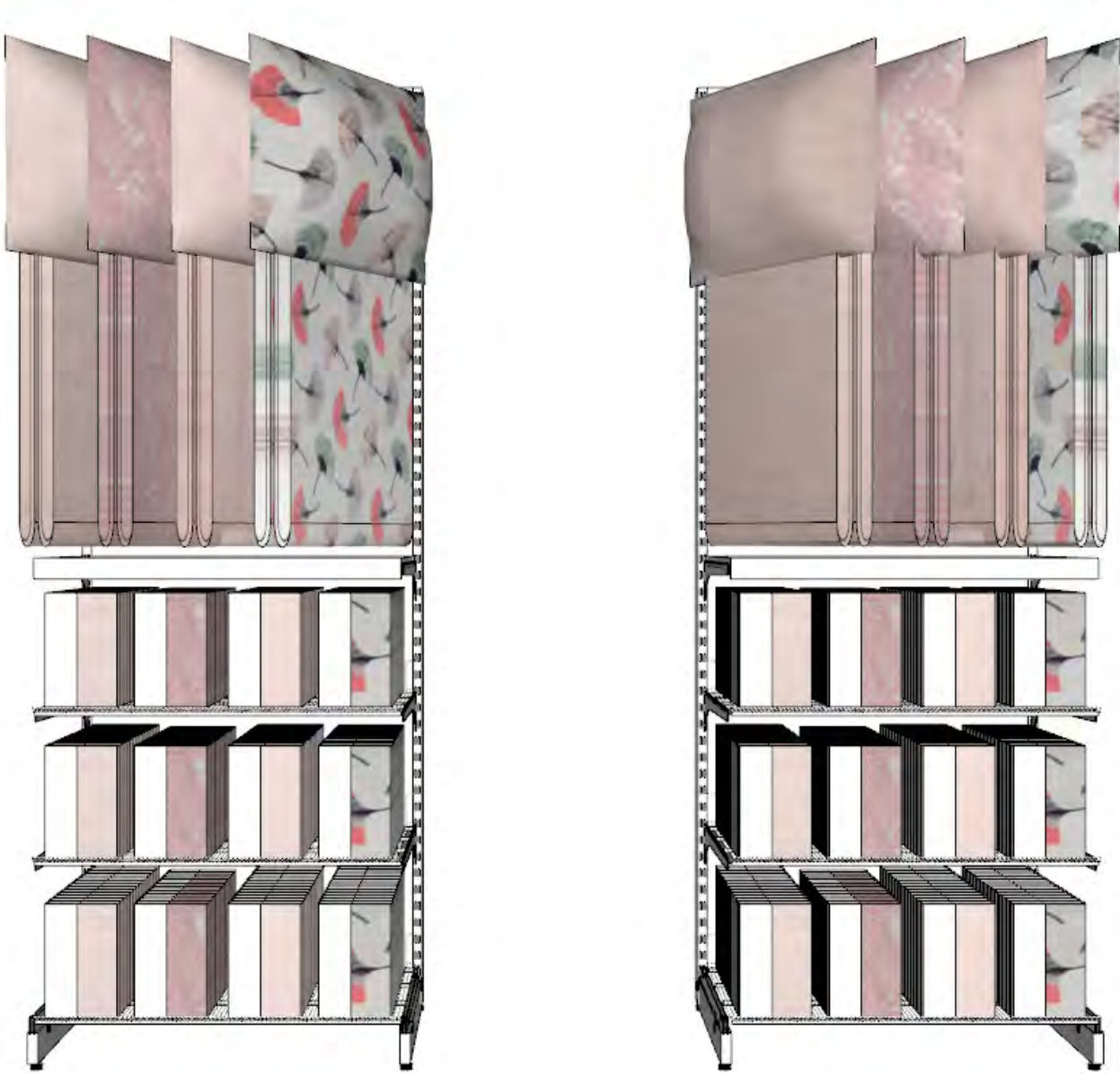

IK607A

# GW1 2020 | Beds | Millwork | Nightstands

- SketchUp file includes all elements: millwork, racking, and displays.
- Please only modify displays and racking.
- Millwork will be available in two heights: 260cm and 290cm
- Options to use Low Partition f Nightstands 160W white or low Display Tables on floor.

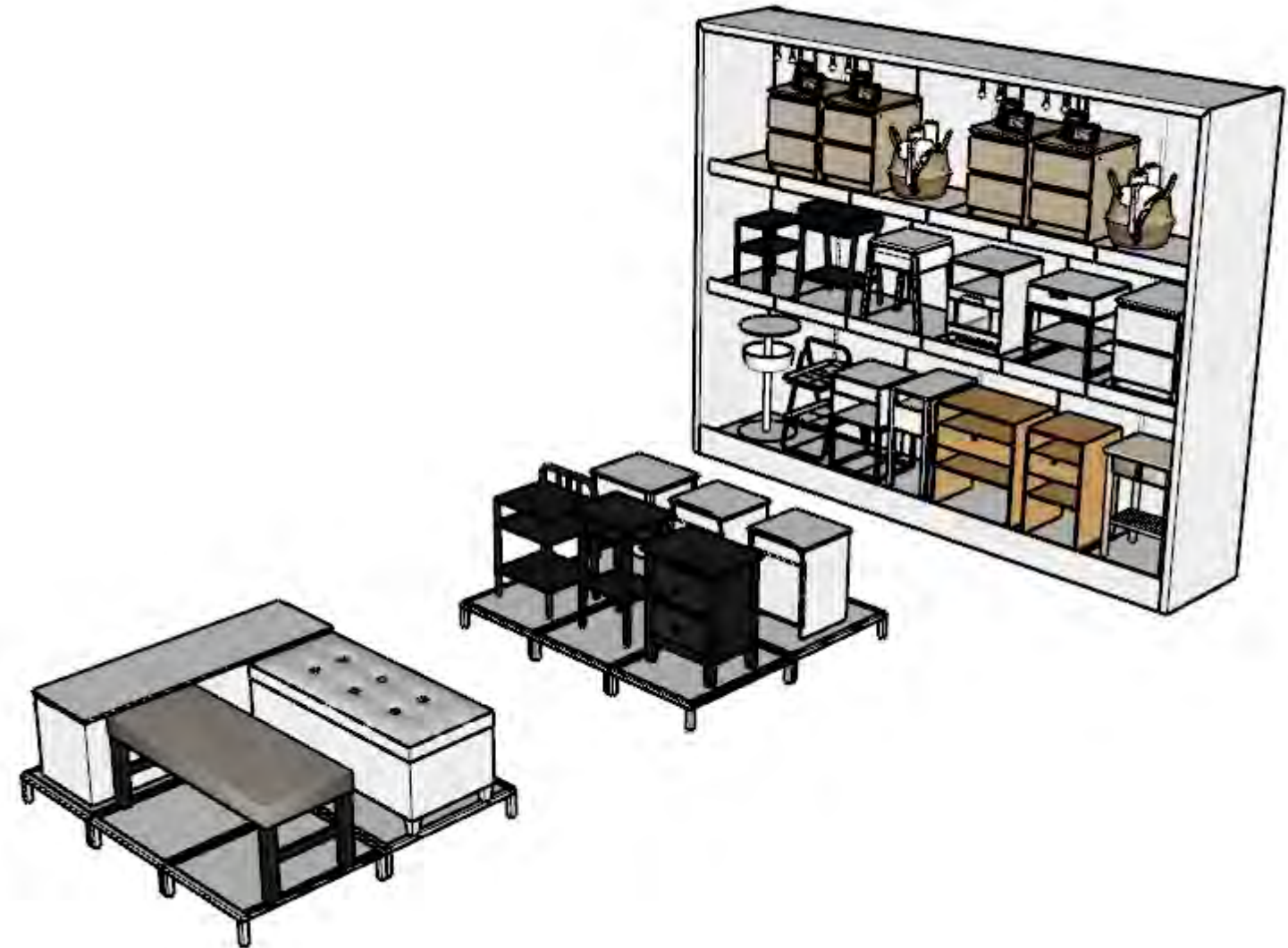

<input checked="" type="checkbox"/> 260H					
<input type="checkbox"/> 290H					
60D	250H	250H	250H	250H	250H
	60D	60D	60D	60D	60D
IK594A					

# GW 2020 | Mattresses

- SketchUp files include all elements: mattress, base, legs, boot guard, pillows, pricing, and plexi stand.

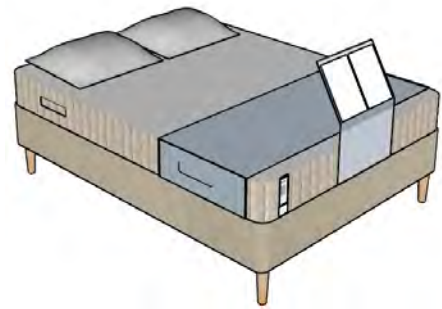

**HASVAG**  
Twin, Full, Queen

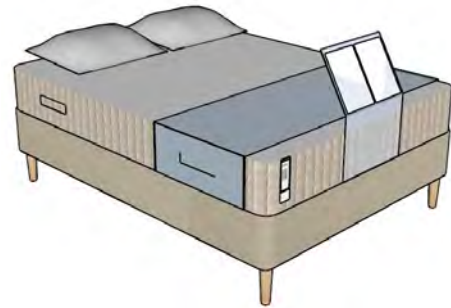

**HAUGESUND**  
Full, Queen

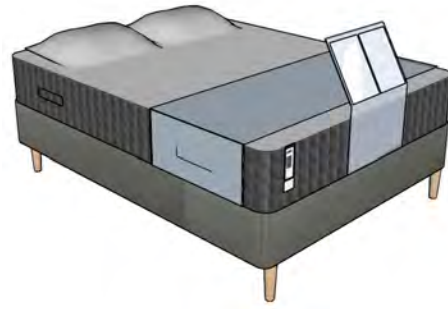

**HAUGSVAR**  
Full, Queen

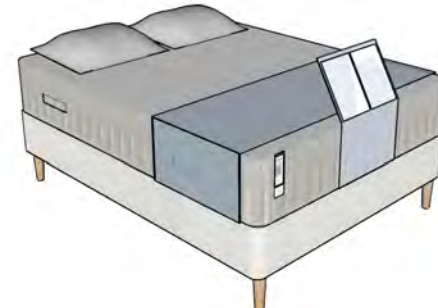

**HESSTUN**  
Full, Queen, King

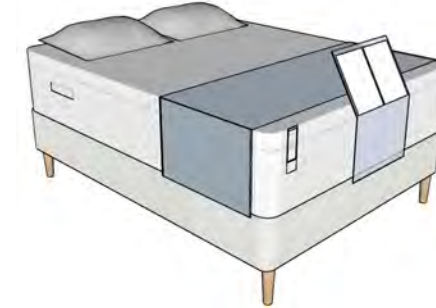

**HJELLSTAD**  
Full, Queen

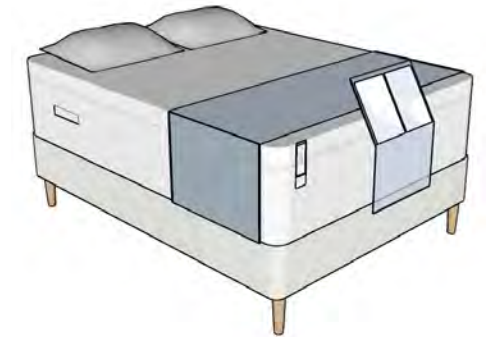

**HOLMSBU**  
Queen

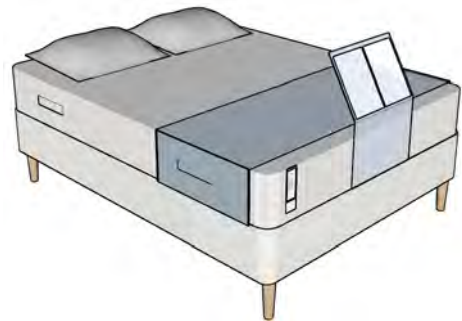

**KNAPSTAD**  
Full, Queen

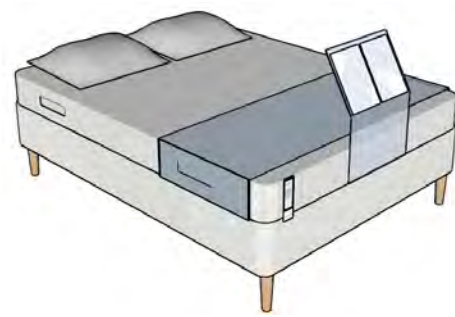

**MATRAN**  
Full, Queen

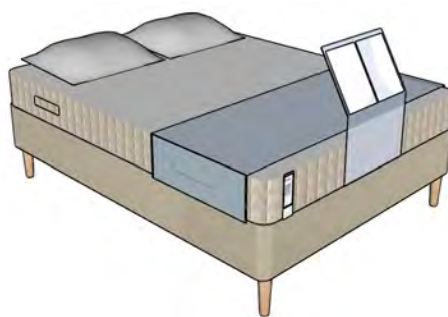

**MAUSUND**  
Full, Queen

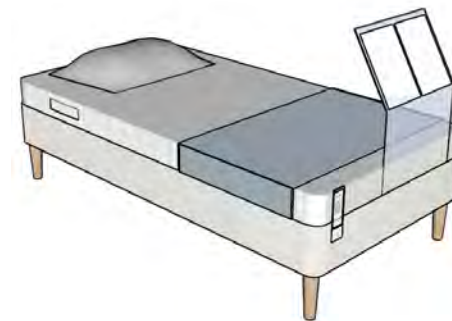

**MEISTERVIK**  
Twin

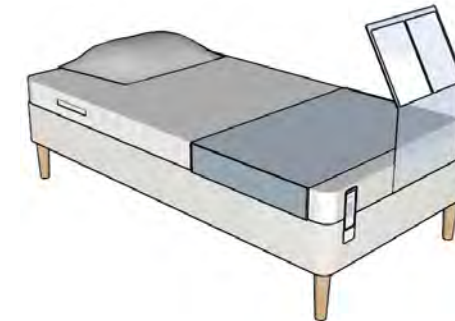

**MINNESUND**  
Twin

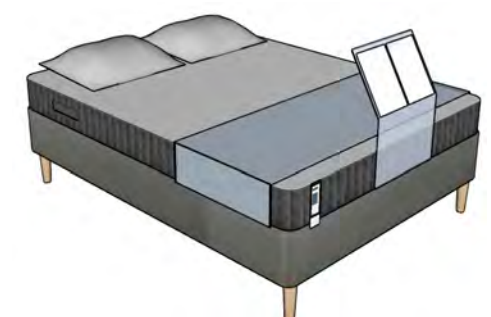

**MORGEDAL**  
Full, Queen

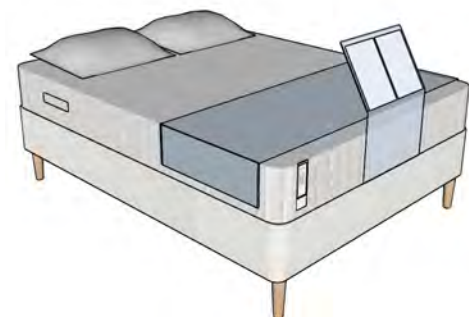

**MYRBACKA**  
Full, Queen, King

## GW 2020 | Mattresses | Millwork | Partitions

- The SketchUp file contains all of the partitions linked together as separate components.
- Partitions will be available in two heights: 260cm and 290cm.
- Place partition block on NOTES layer. Please make sure to let Morten know so he can place on drawing.
- CAD block is dynamic.

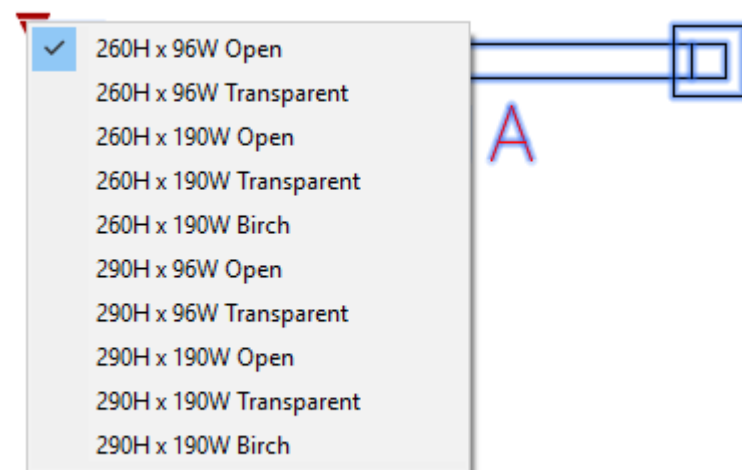
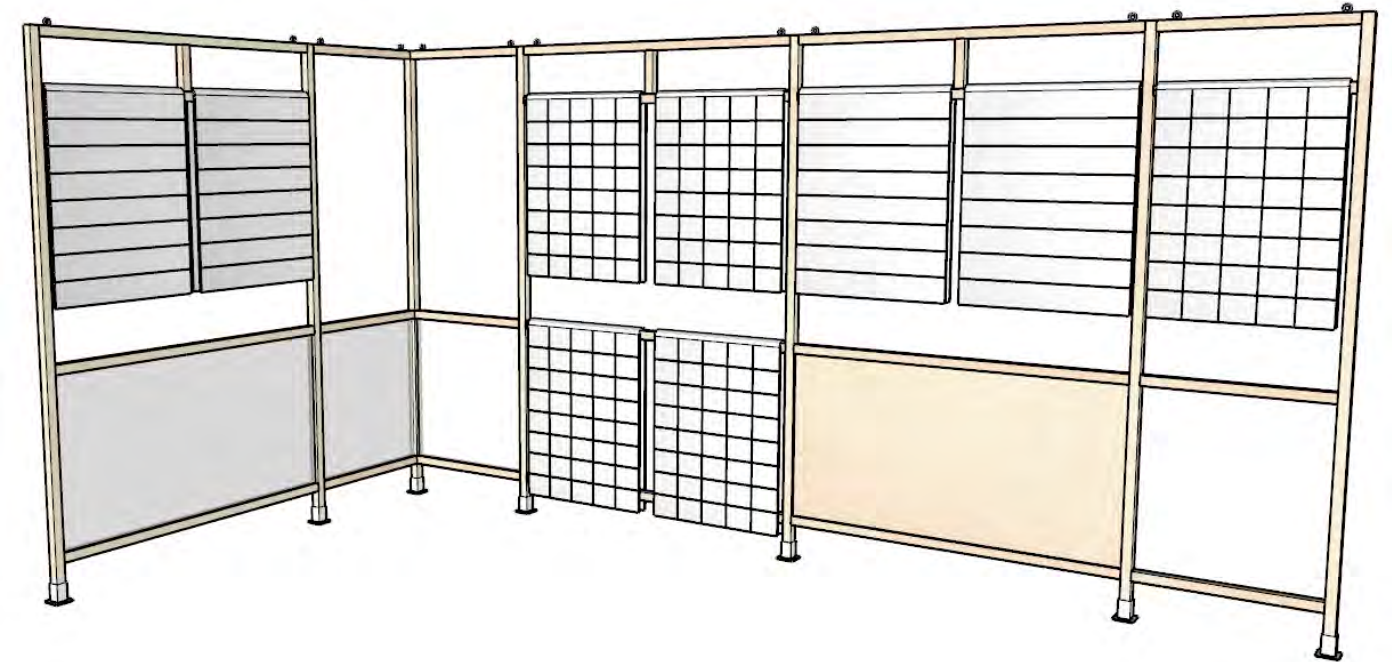
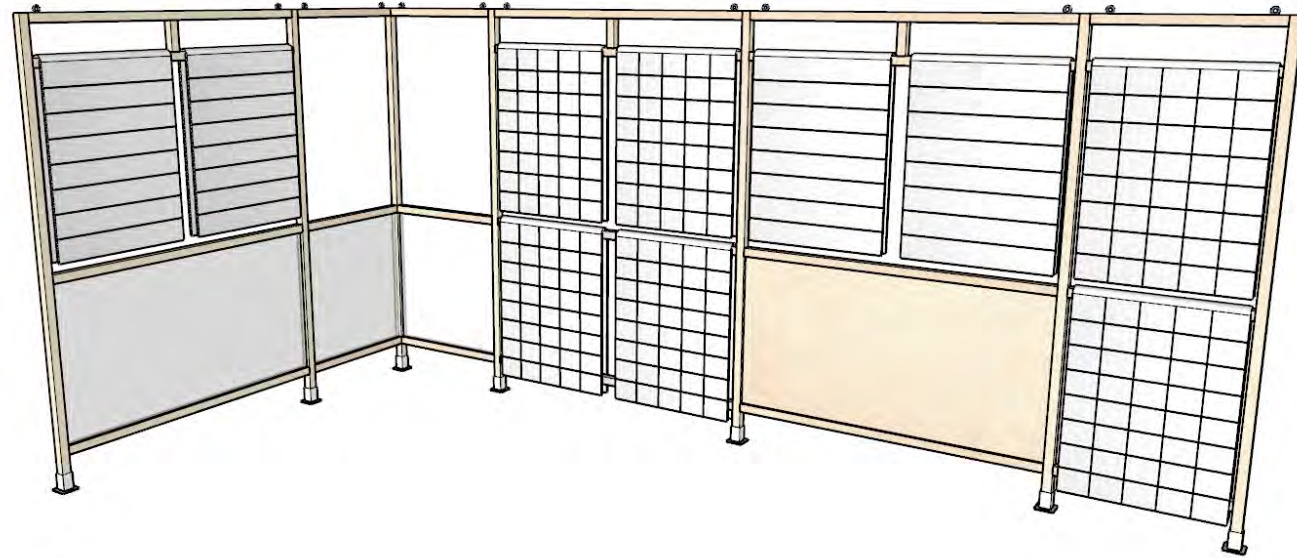

# GW1 2020 | Mattresses | Millwork | Showcase

- SketchUp file includes all elements: millwork, racking, undershelf lighting, and pallets.
- Mattress on podium will need to be placed in layout.
- Place Data and Electric blocks on NOTES layer. Please make sure to let Morten know so he can place on drawing.
- Explode block before creating final PDFs, elements will be on correct layers
- Showcase will be available in two heights: 260cm and 290cm

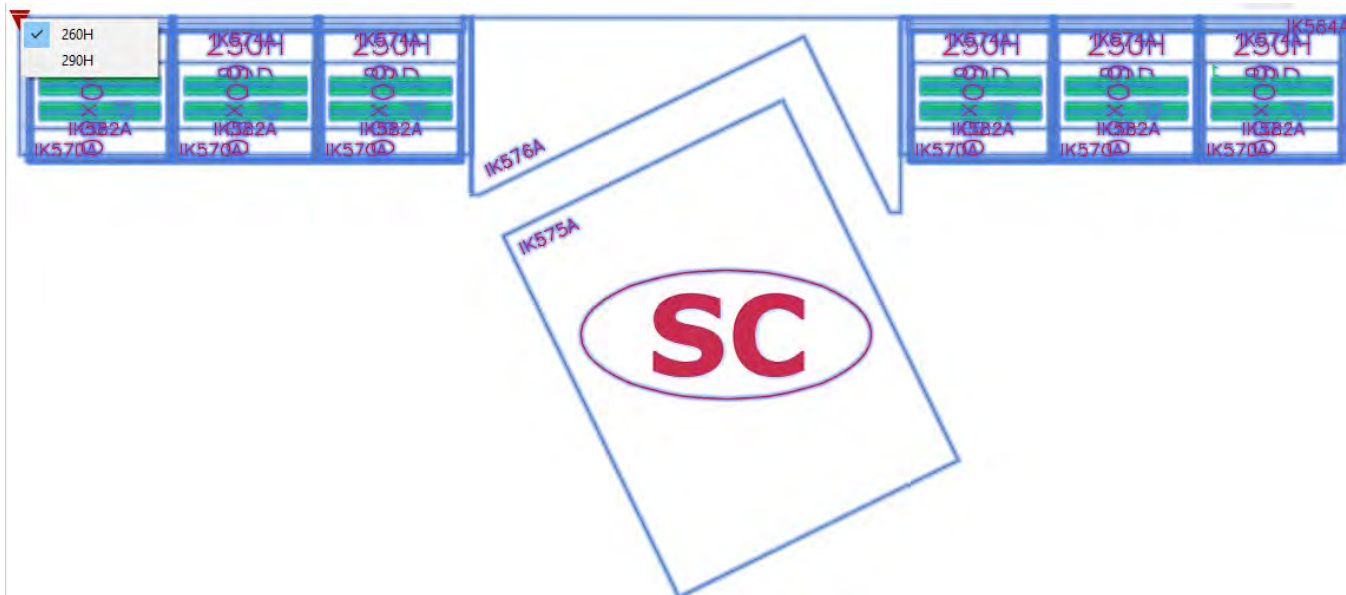

## GW1 2020 | Mattresses | Millwork | Rolled Mattress Podium

- SketchUp file includes all elements: millwork, graphics, and displays.
- Podium should be shown in front of IK578A Partition f Mattresses 260H 190W Birch
  - Place partition block on NOTES layer. Please make sure to let Morten know so he can place on drawing.
- The podium size does not change, however SketchUp files for both 260 and 290 heights of the partition are provided.
- CAD block is dynamic.

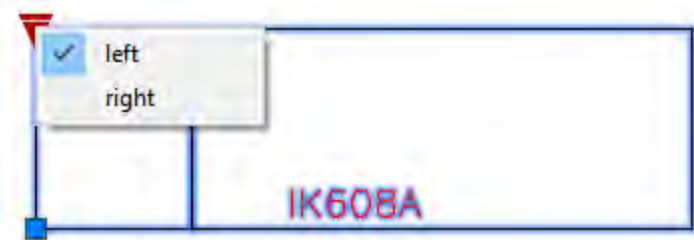
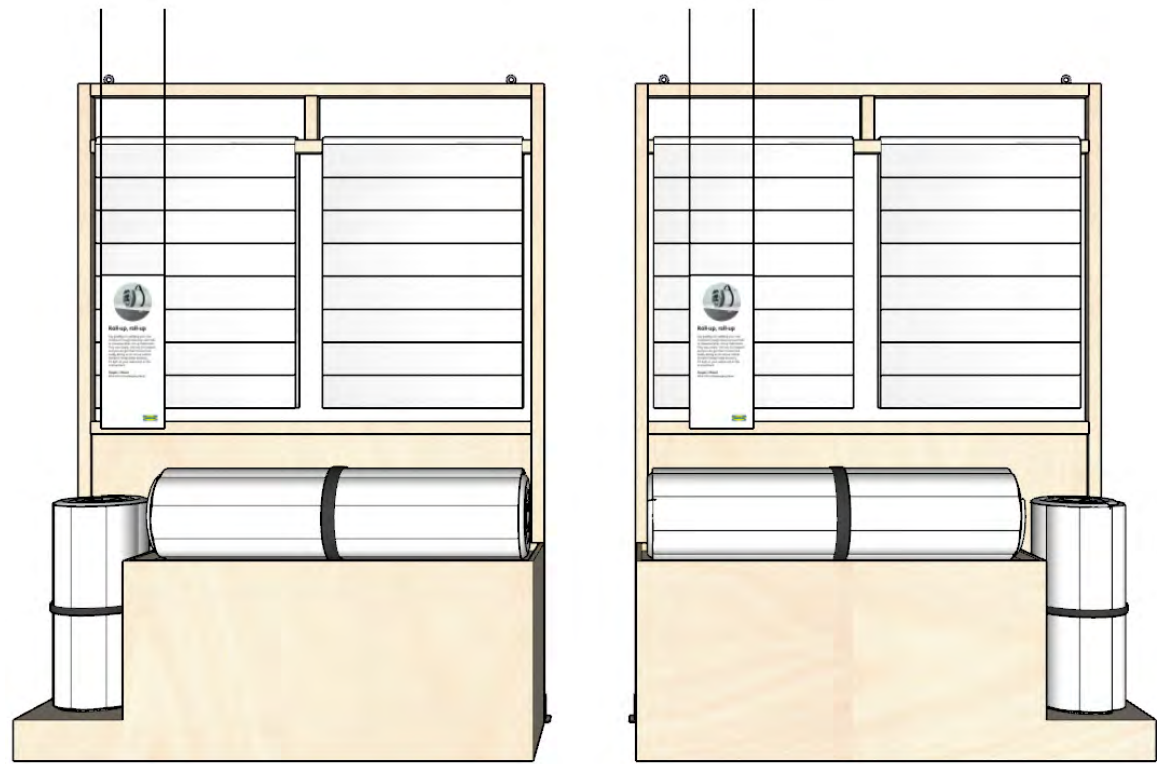

## GW1 2020 | Mattresses | Millwork | Mattress Toppers, Slats & Legs

- SketchUp file includes all elements: millwork, graphics, and displays.
- Mattress Toppers are shown as FULL size
- Use 150x60 sizes for both if you want to show together or on either side of Showcase.
- Use 150x30 size for Slats and Legs if you are showing them separately.
- Mattress Toppers and Slats will have IKEA undershelf lighting installed.
- CAD block for Slats and Legs is dynamic.

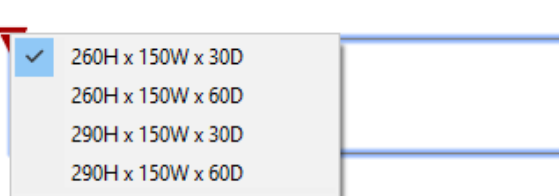
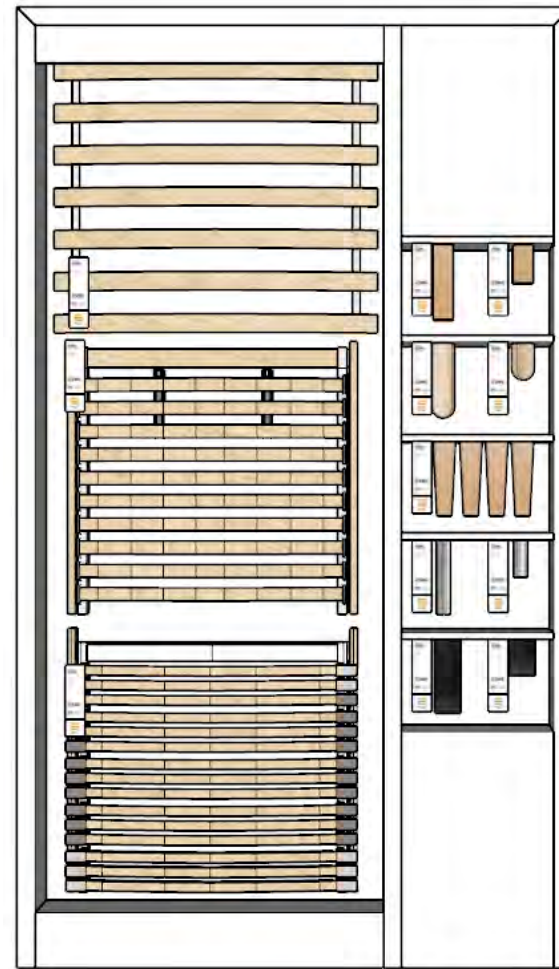
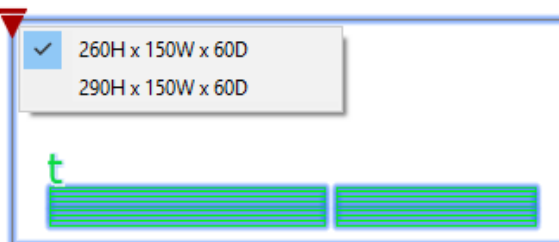

## GW 2020 | Mattresses | Millwork | Low Partitions f Mattresses

- CAD blocks are dynamic.
- Partition sizes match mattress sizes: twin, full, queen, and king.
- Place blocks on NOTES layer. Please make sure to let Morten know so he can place on drawing.

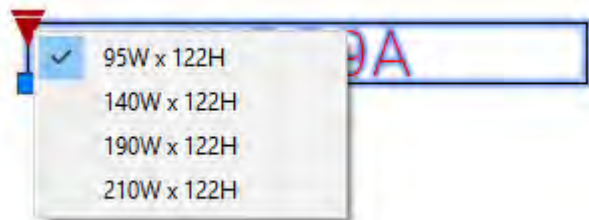

# GWI 2020 | Chest of Drawers | Millwork | Low Partitions

- CAD blocks are dynamic.
- Place blocks on NOTES layer. Please make sure to let Morten know so he can place on drawing.

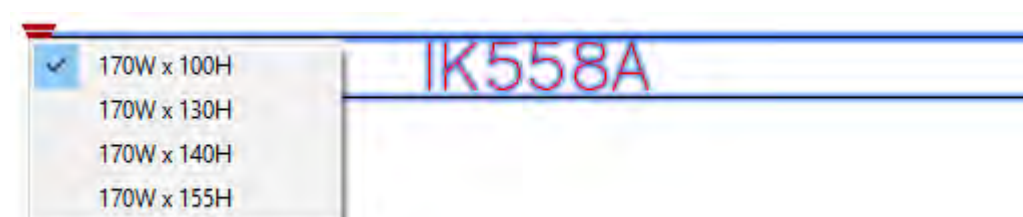
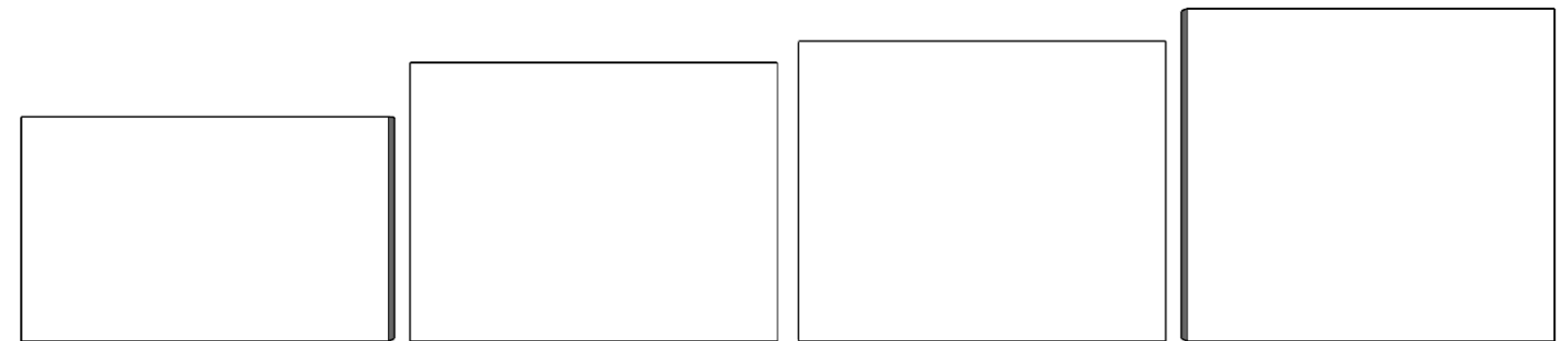
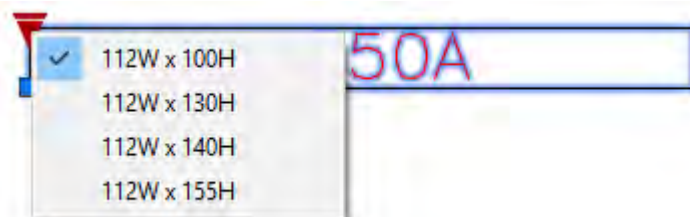
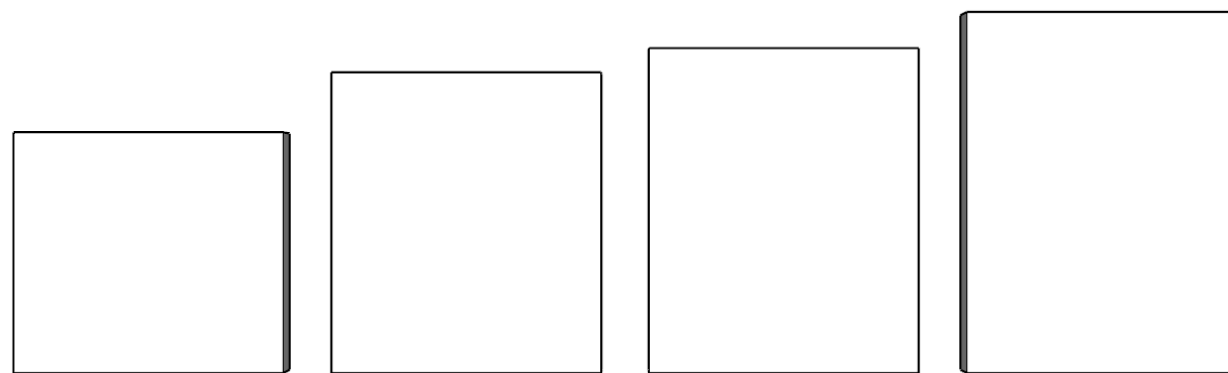
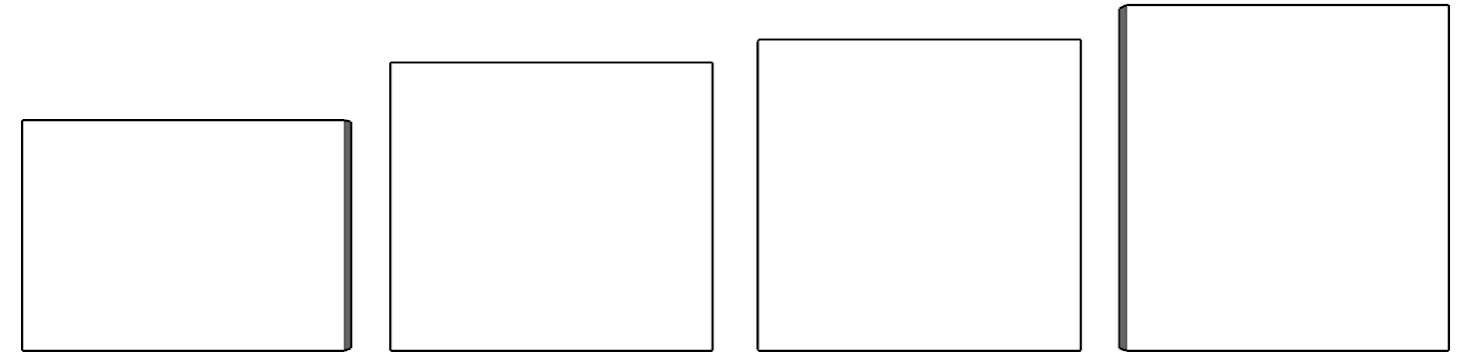
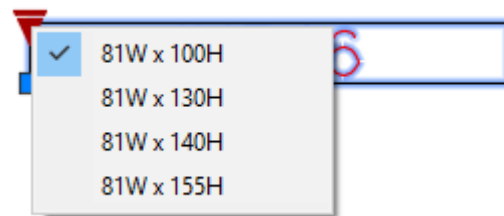
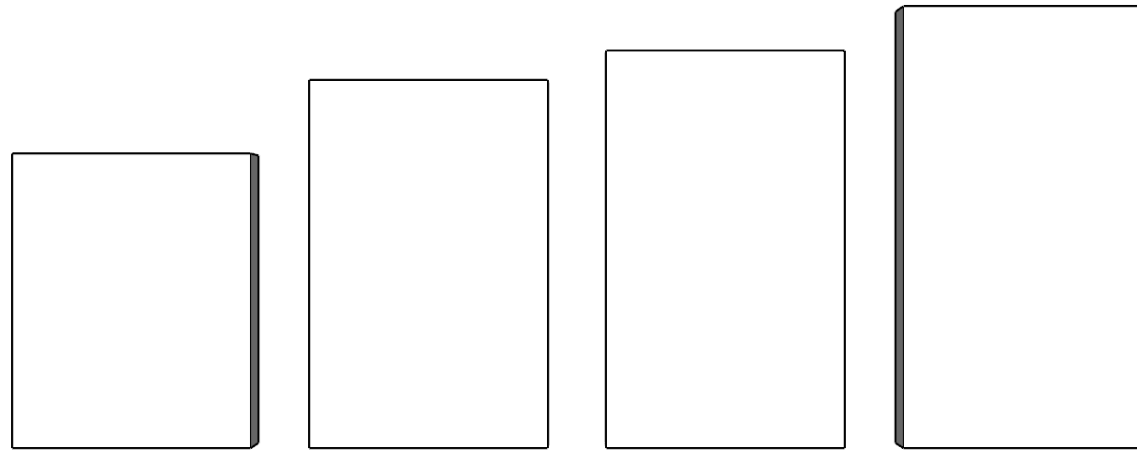

# GWl 2020 | Chest of Drawers | Millwork | Wall Podiums

- Wall Podiums can be used in both Beds and Chest of Drawer compacts.
- To be used in both 260cm and 290cm height stores.
- They are meant to be modular and placed concurrently along the wall to the length needed.

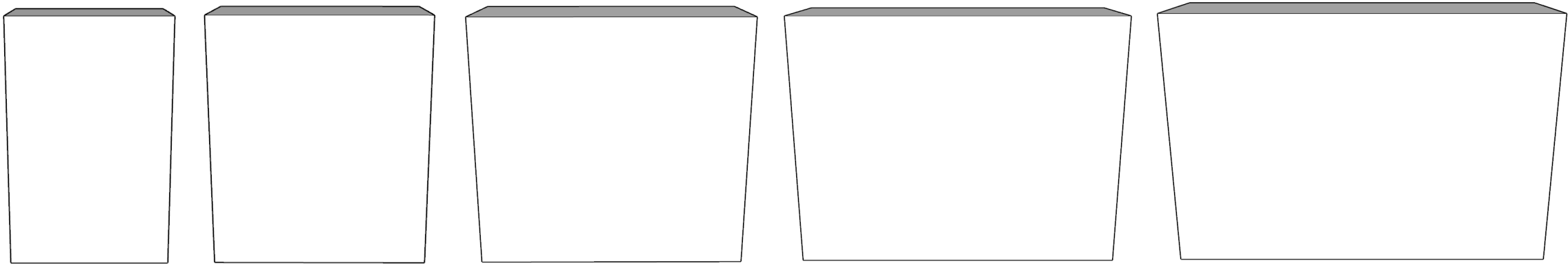

✓ 90W x 140H  
120W x 140H  
150W x 140H  
180W x 140H  
210W x 140H



IK531A

## GW 2020 | Storage | Millwork | Arches

- Reach-In Closet Arches can be used for closet and Secondary Storage solutions
- Optional Under Stairs Wedge can be attached to inside of Reach-In Closet Arches only.
- To be used in both 260cm and 290cm height stores.
- Arch f ELVARLI is used to show adjustable height.
- CAD blocks are dynamic.

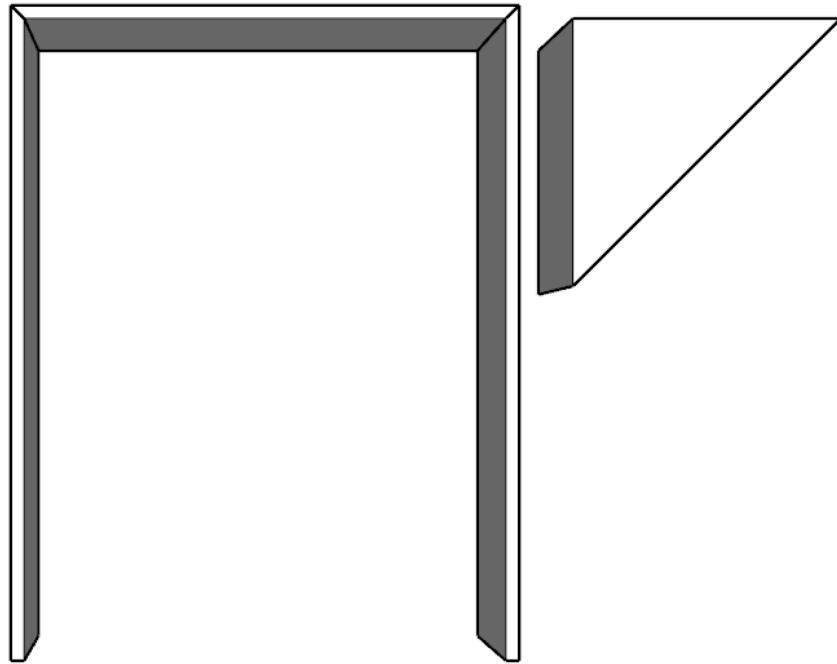

Arch f Reach-In Closet

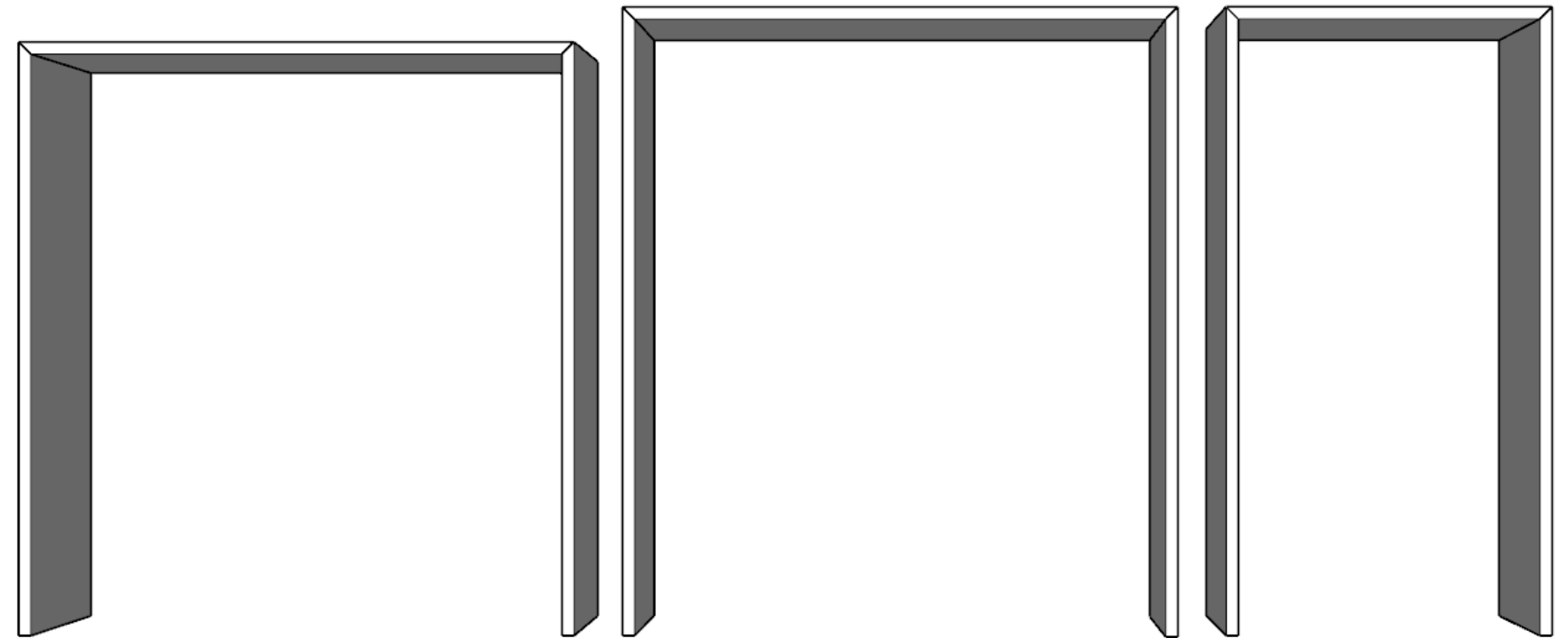
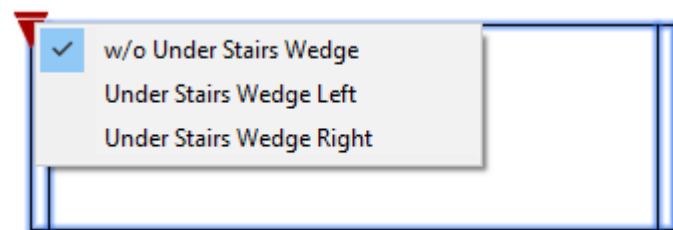

Arch f ELVARLI

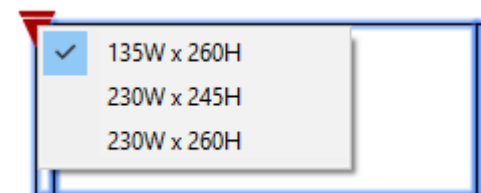

# GWl 2020 | Storage | Millwork | Showcase

- SketchUp file includes all elements: millwork, racking, digital, props, and displays.
- Showcases will be available in two heights: 260cm and 290cm
- CAD blocks include faay wall on NOTES layer. Please make sure to let Morten know so he can place on drawing.

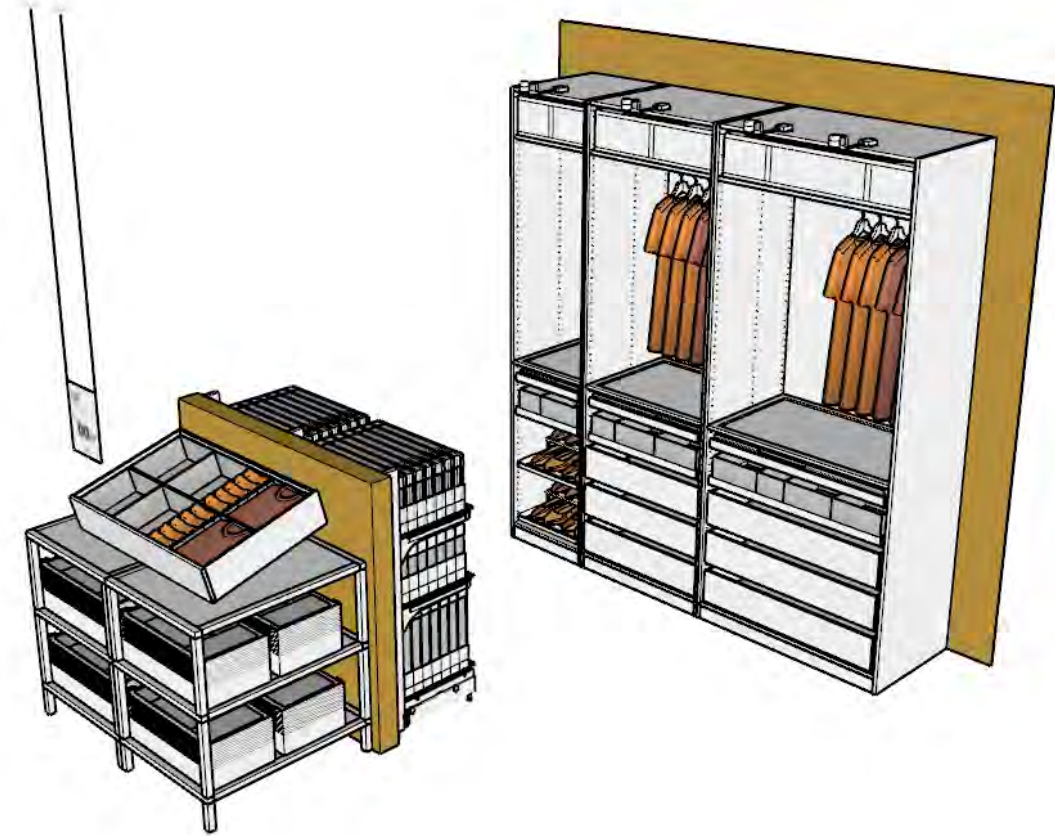

# GW 2020 | Storage | Millwork | PAX Door Menus

- SketchUp file includes all elements: millwork, racking, signage, and displays.
- Please only modify displays.
- Menus are available in two heights: 260cm and 290cm
- Sliding Door Menu are available in both left and right facings.
- CAD blocks are dynamic.

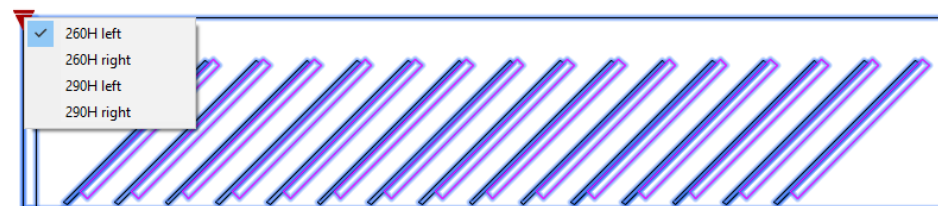
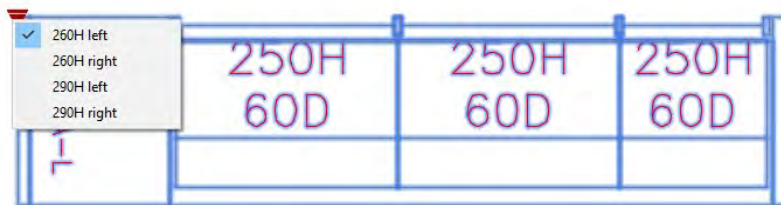

## GWl 2020 | Planning | Millwork | Partitions

- The SketchUp file contains all of the partitions linked together as separate components.
- Partitions will be available in two heights: 260cm and 290cm.
- Place partition block on NOTES layer. Please make sure to let Morten know so he can place on drawing.
- CAD block is dynamic.

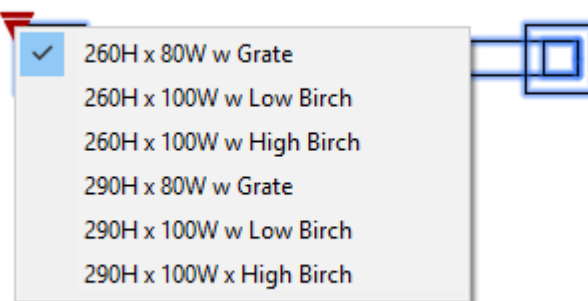
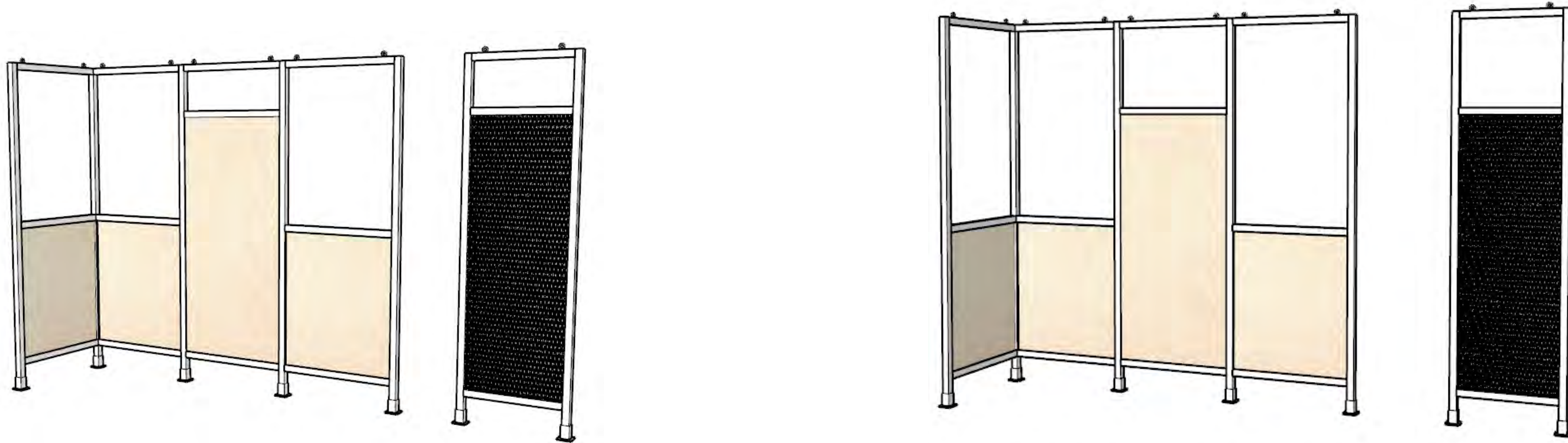

## GW 2020 | Planning | Millwork | Planning Desks f Wall

- SketchUp file includes all elements: millwork, digital, signage, and displays.
- The desks come in two lengths, 200cm and 350cm. They can be placed next to each other along a wall to create a longer surface.
- Place Birch Wall Panels on wall behind desks.
- CAD block is dynamic.

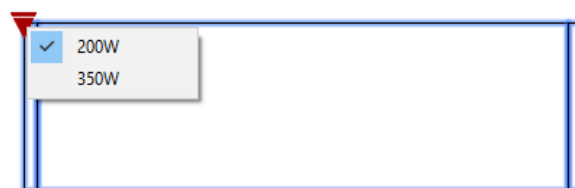
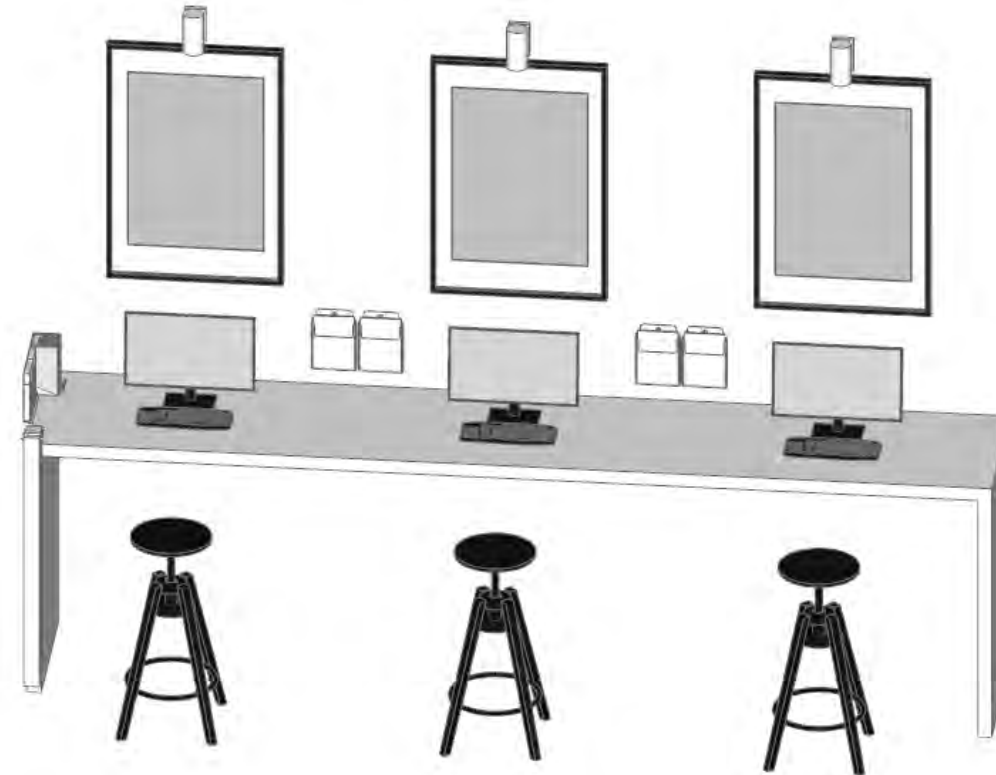

IK604A

# GW1 2020 | Planning | Millwork | Planning Desk Freestanding

- SketchUp file includes all elements: millwork, digital, and displays.
- CAD blocks include power pole on NOTES layer. Please make sure to let Morten know so he can place on drawing.



Front



Back

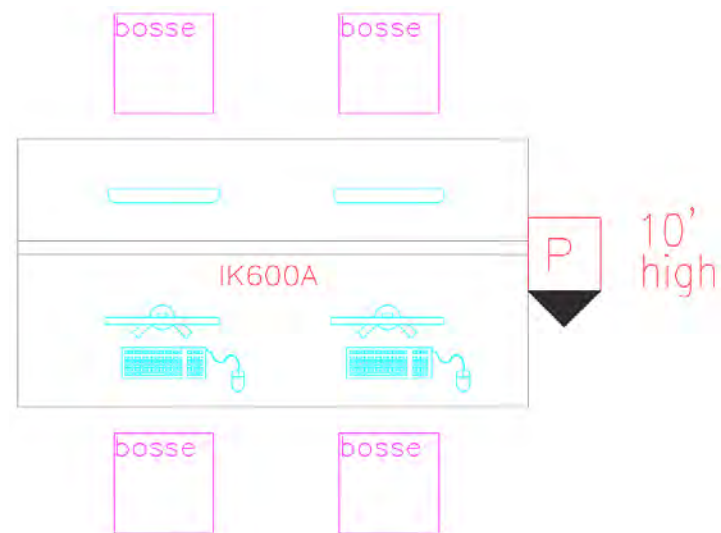

- SketchUp file includes all elements: millwork, racking, displays, graphics, props, and add-ons.
- No CAD blocks have been created.

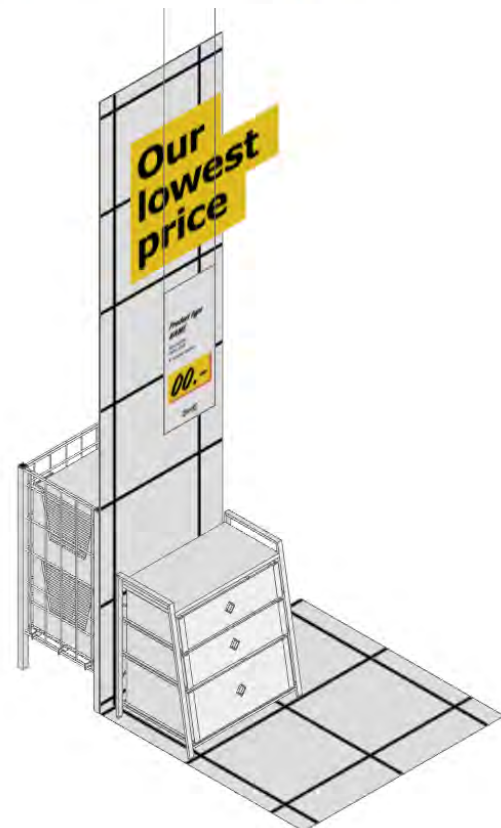
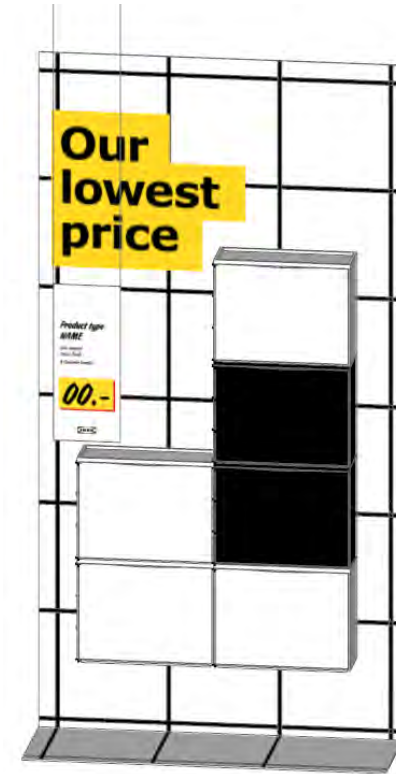

# GW1 2020 | Media | Perimeter Breaks

- SketchUp file includes all elements: millwork, racking, displays, graphics, props, and add-ons.
- Available in two heights: 260cm and 290cm



# GW1 2020 | Media | Coordination Areas

- SketchUp file includes all elements: millwork, racking, add-ons, props, and displays.
- Low Partitions and Wall Podiums specific to media are included in the blocks.
- CAD blocks include power pole on NOTES layer. Please make sure to let Morten know so he can place on drawing.
- 260cm height will be used in all stores.

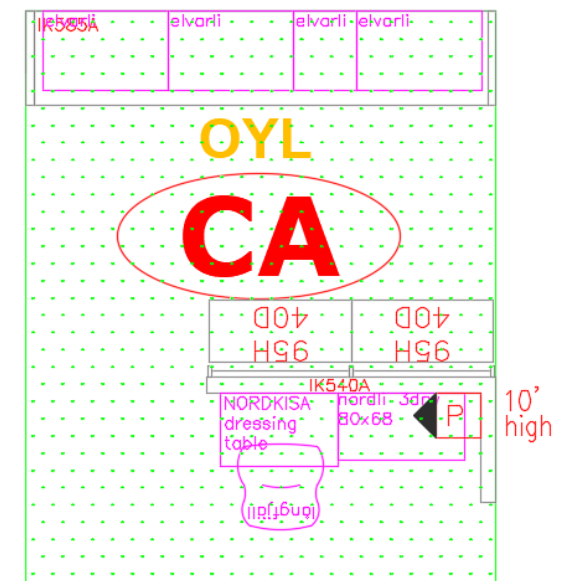
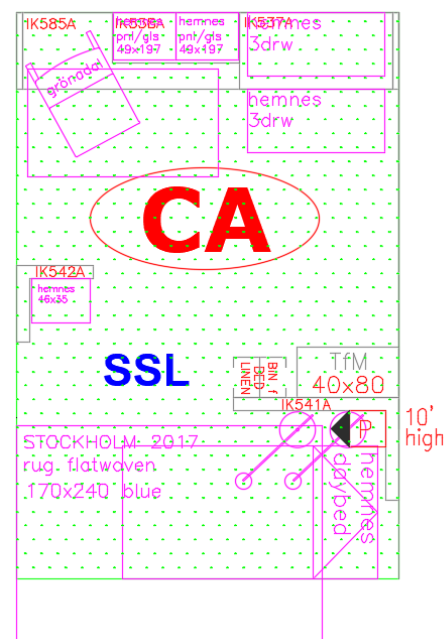
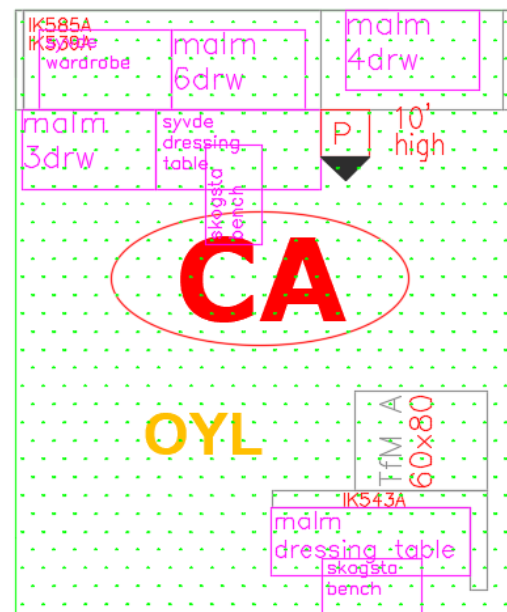

- WTS graphics for Mattress Studio
- Size is 180cm x 260cm or 260cm x 260cm (size doesn't change for 290 stores)

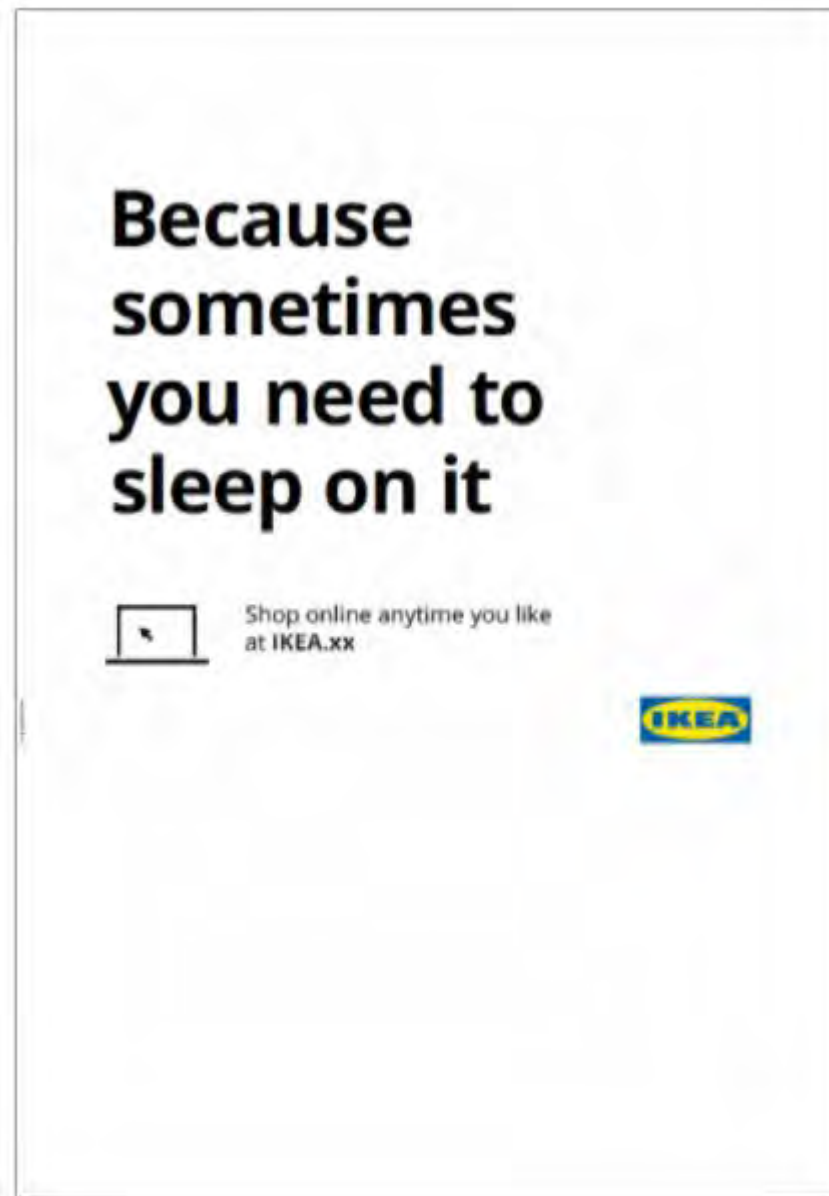

- SketchUp components pulled together for ease of use.

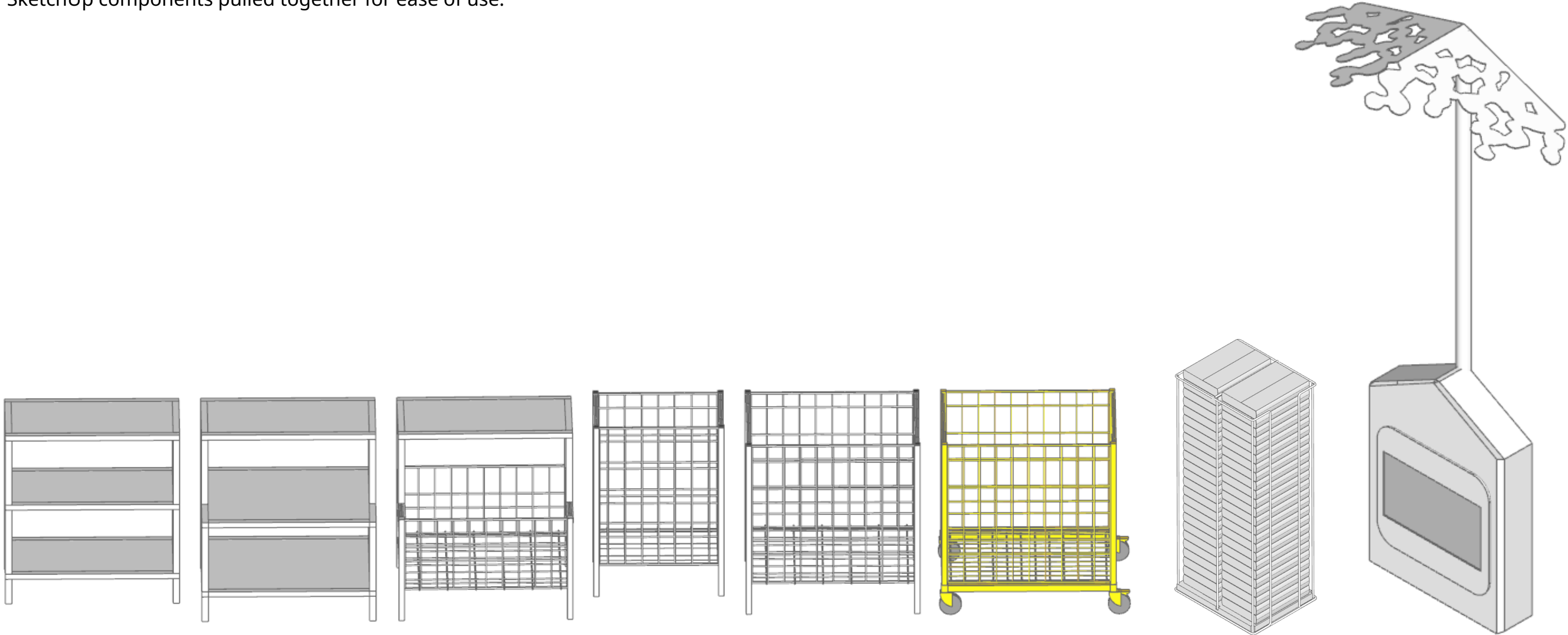

- SketchUp file includes all elements: millwork, digital.
- CAD blocks are separate:
  - Place Sales Counter, Credit Card Kiosk, and Touchscreen on Stand on CUSTOMCONV layer
  - Call to Action Lightbox on COMMUNICATION layer
  - Power Pole on NOTES layer. Please make sure to let Morten know so he can place on drawing.

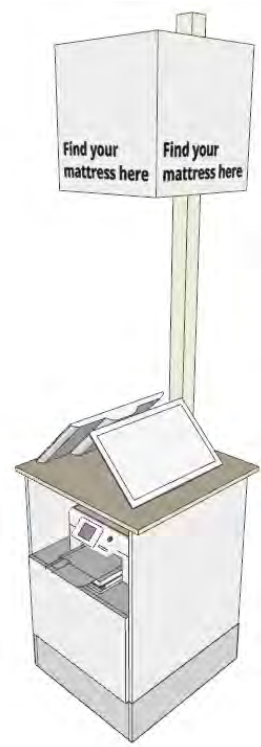

Mattress Sales Counter

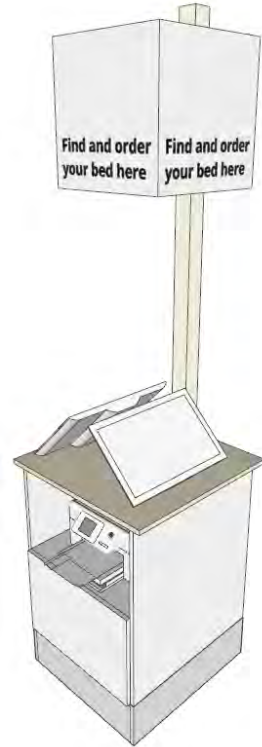

Bedframes Sales Counter



Credit Card Kiosk

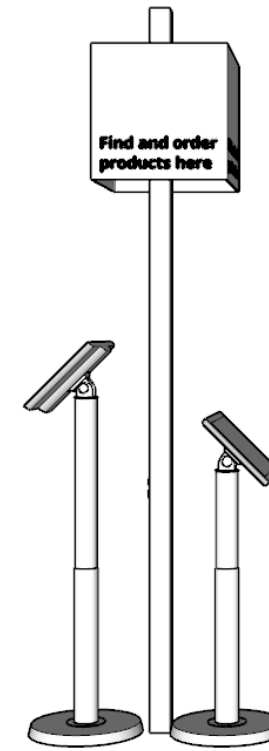

HITTA touchscreens

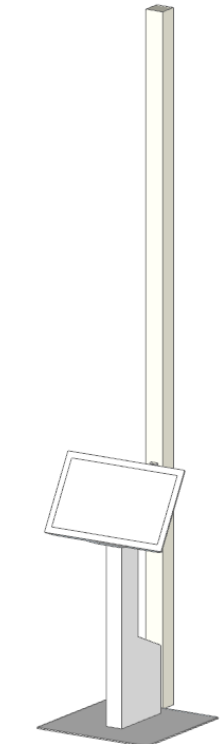
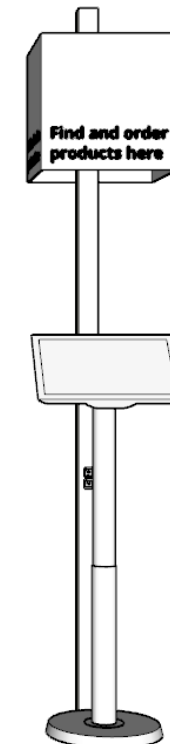

FIRST Kiosk

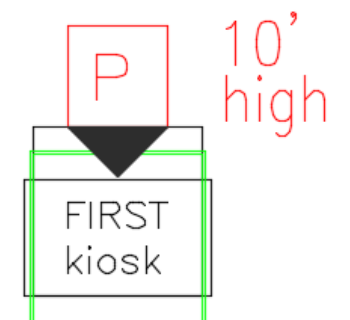
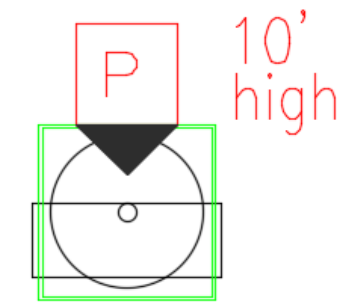
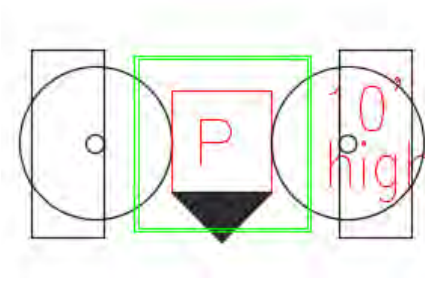
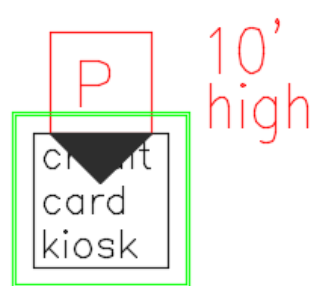
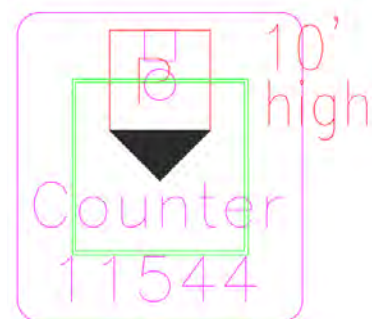
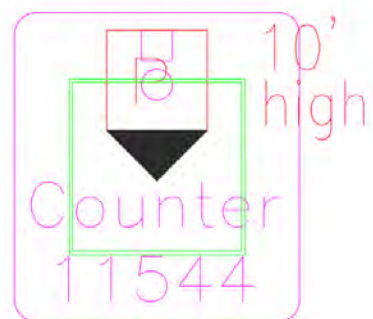

	Touchscreens						Computers	
	Bed Configurator w/ Table Stand	Mattress Guide w/ Table Stand	First w/ Table stand	HITTA on Floor Stand	FIRST Kiosk w/ Floor Stand	Credit Card Kiosk	PAX Planner	MHS Computer
Room Block 1								
Room Block 2								
Beds	●							
Mattresses		●				●		
COD								
Planning			●	●		●	●	●
PAX								
Storage					●			

	Printers		Zeta			Share Home Furnishing Knowledge Screen - 13"	Home Communcation 32" Screen	Secure it! Television w/ Media Player
	B/W	Color	Showcase Landscape - Angle	Showcase Portrait	Perimeter Break projector			
Room Block 1						●		
Room Block 2						●	●	
Beds		●			●			
Mattresses	●		●					
COD								●
Planning		●						
PAX				●				
Storage					●			

- All Data and Electric to be placed on NOTES layer. Please make sure to let Morten know so he can place on drawing.
- Power Poles are included in CA blocks.
- Use this guide to ensure proper data and electrical needs are indicated. These are for example only, please adjust as needed.



Digital Shopping Tools:

- 3 Data
- 1 Voice
- 24/7 power
- 1 printer
- Power pole

Credit Card Kiosk:

- 24/7 power
- Wall outlet or power pole

# GW1 2020 | Data and Electric | Mattresses

- All Data and Electric to be placed on NOTES layer. Please make sure to let Morten know so he can place on drawing.
- Power Poles are included in CA blocks.
- Use this guide to ensure proper data and electrical needs are indicated. These are for example only, please adjust as needed.

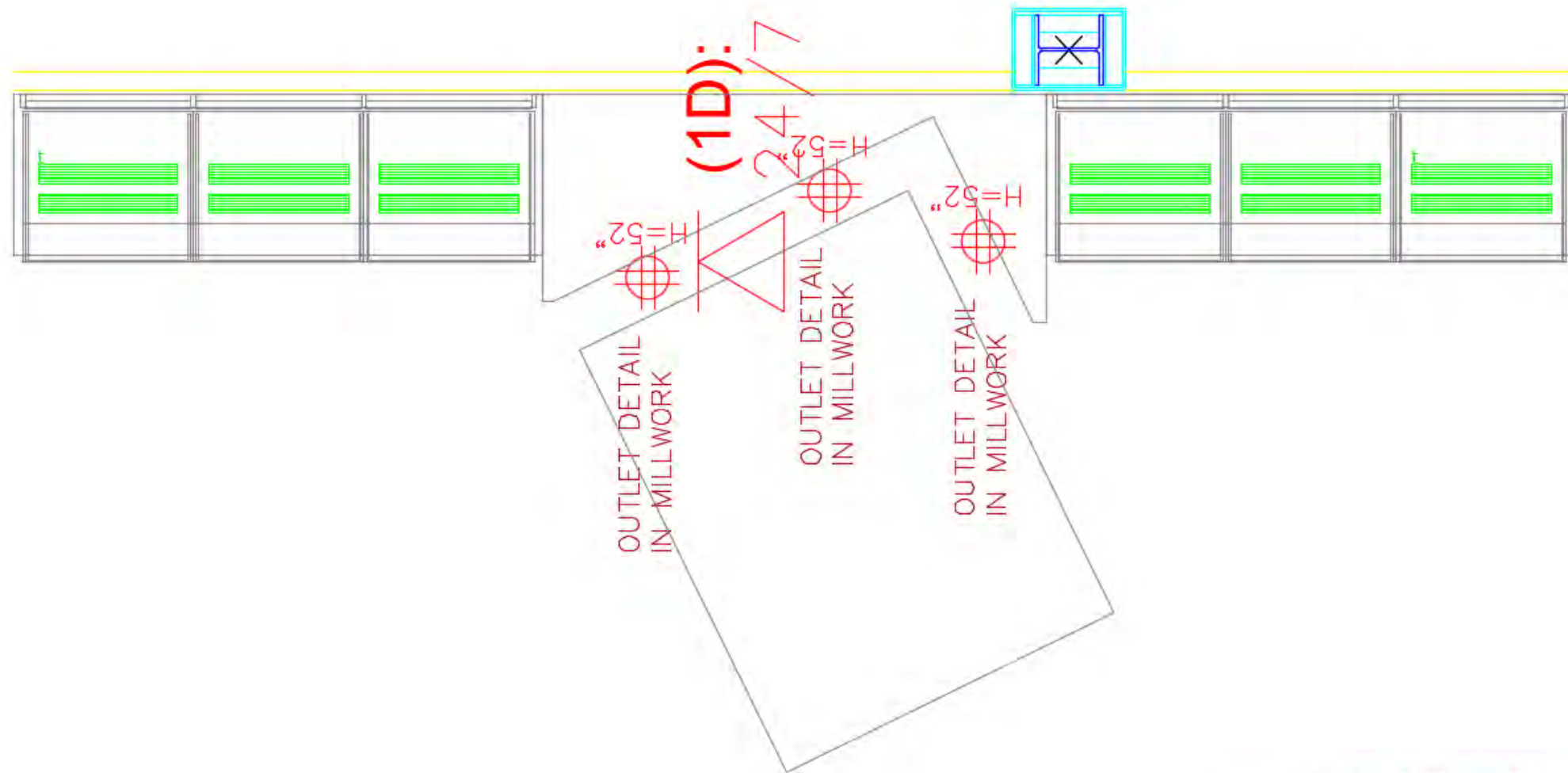

### Mattress Showcase:

- 1 Data
- 24/7 power
- 3 outlets w/ 4 plugs at 52" H



### Credit Card Kiosk:

- 24/7 power
- Wall outlet or power pole



### Digital Shopping Tools:

- 3 Data
- 1 Voice
- 24/7 power
- 1 printer
- Power pole

- All Data and Electric to be placed on NOTES layer. Please make sure to let Morten know so he can place on drawing.
- Power Poles are included in CA blocks.
- Use this guide to ensure proper data and electrical needs are indicated. These are for example only, please adjust as needed.

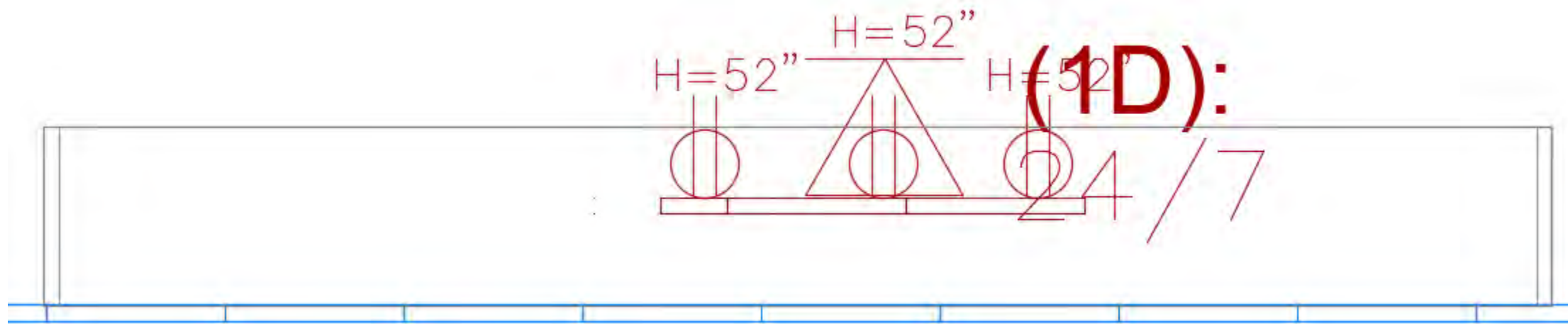

PAX Showcase:

- 1 Data
- 24/7 power
- 3 outlets at 52" H

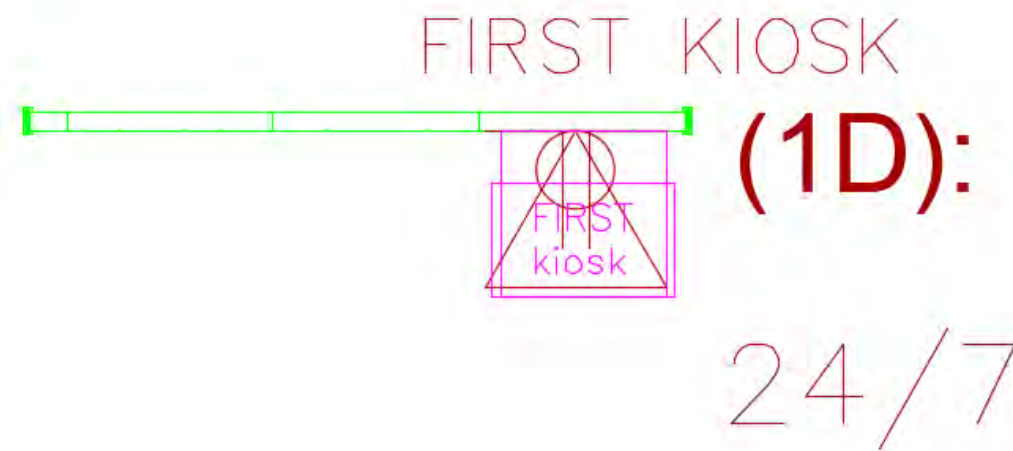
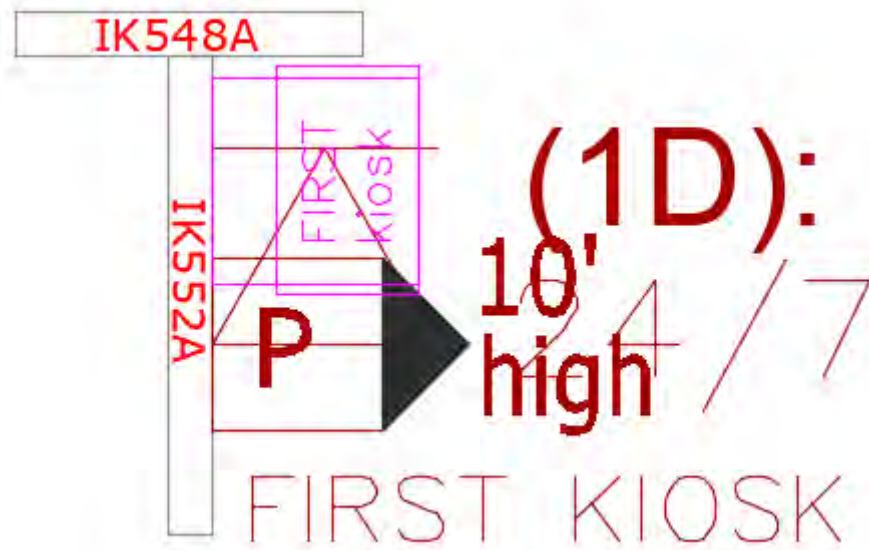

FIRST Kiosk:

- 1 Data
- 24/7 power
- Wall outlet or power pole

- All Data and Electric to be placed on NOTES layer. Please make sure to let Morten know so he can place on drawing.
- Power Poles are included in CA blocks.
- Use this guide to ensure proper data and electrical needs are indicated. These are for example only, please adjust as needed.

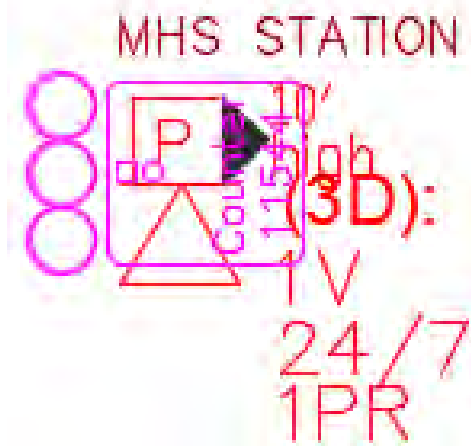

**Digital Shopping Tools:**

- 3 Data
- 1 Voice
- 24/7 power
- 1 printer
- Power pole

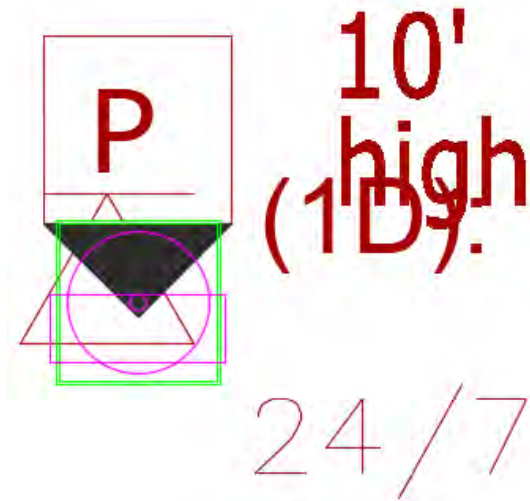

**HITTA:**

- 1 Data
- 24/7 power
- Power pole



**Credit Card Kiosk:**

- 24/7 power
- Wall outlet or power pole

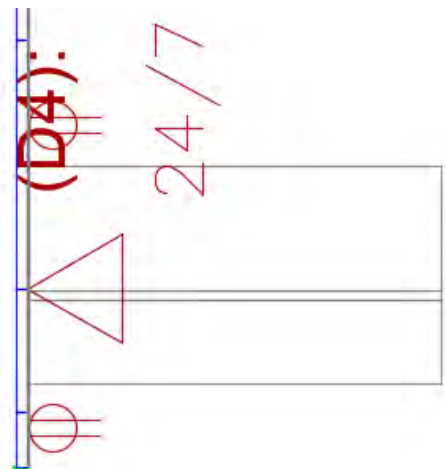

**Freestanding desk:**

- 4 Data
- 24/7 power
- Wall outlets or power pole

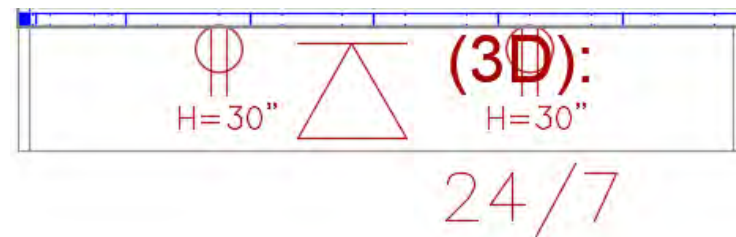

**Wall desk:**

- 2-3 Data
- 24/7 power
- Wall outlets at 30"H

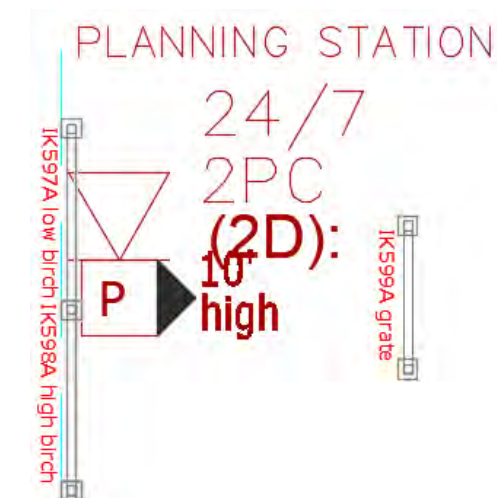

**Planning Desks:**

- 2 Data
- 24/7 power
- Power pole

# TACK!

